

# HX | MX Series

## Swingaway Augers





## Hutchinson | Mayrath **Unmatched Performance**

Hutchinson | Mayrath is committed to providing farmers with industry leading products. The HX and MX Series features over 75 farm-proven performance enhancements designed to make your job easier. The HX and MX swingaway augers feature a heavy-duty scissor-lift frame, commercial strength trussing and low-profile hopper. Hutchinson hopper, and AR flighting in high wear areas.



**HX100 | MX100**  
63'- 83' LENGTH | CAPACITY UP TO 6,600 BPH

**HX130 | MX130**  
74'- 94' LENGTH | CAPACITY UP TO 11,500 BPH

## Features

### EXTENDED WEAR

The HX and MX Series features an Extended Wear package that offers abrasive resistant flighting on all areas including the hopper flight, transitional flight, incline tube flight, and lower tube flight.

### ENHANCED OPERATION

To ensure proper flight alignment for smooth operation, the HX and MX Series use square, one-bolt flight connections. The upper flight thrust adjuster balances the pressure between the upper and lower bearings during operation - extending the lifespan of the lower boot bearing. The CV PTO reduces vibration and enhances power transfer to the auger, improving the lifespan of the auger without sacrificing capacity. The large boot and tapered boot flight maximize auger capacity at all angles by efficiently channeling grain from the hopper into the auger.

### REDUCED MAINTENANCE

The HX and MX Series are easy to service and maintain with six accessible service points to the u-joints, chains, bearings, and gearboxes along with external grease zerks on the u-joint end caps. With inspection of tool free areas that include the hopper chain cover, neck transition, boot clean-out and swing head cover, these features deliver quick maintenance.

### CORROSION RESISTANT GALVANIZATION

Hutchinson | Mayrath uses a specialized corrosion resistant galvanization on tube housings, for lasting protection and clean finish. All other parts have a premium powder coat paint for long lasting protection.

### TRUSSING & FRAME

The HX and MX Series feature a scissor lift frame and cross members to maximize reach and reduce swaying while the auger is in use. Hutchinson | Mayrath uses commercial strength cable or steel trussing, depending on the model, allowing the auger to be easily aligned and placed into position without swaying or bowing during use.

### HOPPER & HOPPER LIFT ARM

The hopper lift arm and hopper can be positioned on the left or right hand side of the auger to easily unload grain from either side. The hopper features dual flighting that allows the grain to be directed to the center of the hopper, optimizing grain flow to the tapered boot – maximizing capacity and minimizing unload time. The 6" rubber extensions along the edge of the hopper prevents grain from splashing.

AR SINGLE FLIGHT AT TRANSITION & INCLINE FLIGHT

HX130

AR DOUBLE FLIGHT AT INLET HOPPER

AR SINGLE FLIGHT IN LOW PROFILE HOPPER

## Optional Features

### POWER SWING – HYDRAULIC OR ELECTRIC REMOTE

- Two-wheel drive design and large lug tires for maximum traction and balance
- Mounts easily to low profile hopper
- Minimal height adjustment needed when using different heights
- Redesigned scissor lift to adjust wheel traction

### HYDRAULIC POWER SWING

- Hydraulic drive moves the swing hopper
- Convenient tube mounted control valve
- Complete with hydraulic hoses

### REMOTE 12V ELECTRIC POWER SWING

- Heavy-duty 12V motor
- Position the hopper from the cab of your truck
- Large "easy grip" remote
- Secondary control on the tube if remote is not available

### WORKING LIGHT KITS

LED working lights provide enhanced lighting conditions at the hopper, axle, and tube discharge to the bin during operation in low-light conditions.

### RIGHT-ANGLE DRIVE

The right-angle drive positions the auger at a 90-degree angle from the truck while working in small spaces.

### REDUCER-REVERSER

The reducer feature lowers the speed of tractors with 1,000 RMP to 540 RPM, which is required for auger operations.

The reversing feature allows the flight direction to reverse for a quick and easy cleanout and saves time when moving from one commodity to the next. The reverser kit is also available on its own without the speed reducer.



### HX100 | MX100 AUGER SPECIFICATIONS

	10-63	10-73	10-83
TUBING GAUGE	12 GA		
TUBE CONNECTORS	Heavy Duty $\frac{3}{16}$ " Angle Flange		
MAIN FLIGHTING	9" OD x 7 GA Stretched + Welded (Extended Wear at Critical Transfer Points)		
FLIGHTING SHAFT	High Strength 2" OD x 11 GA Tubing		
UPPER BEARING	1 $\frac{1}{4}$ " Pillow Block Greaseable Ball Bearing		
LOWER BEARING	1 $\frac{1}{2}$ " Pillow Block Greaseable Ball Bearing		
TUBE TRUSSING	$\frac{3}{8}$ " Aircraft Type Galvanized Steel Cable		
HYDRAULIC LIFT	4" Single Acting Cylinder		
UNDERCARRIAGE	4" x 8" Scissor Lift		
AXLE	3" x 6" Tubing		
HUBE	6-Bolt Agricultural Type		
TIRES	16" TRF		
PTO SHAFT	14E Constant Velocity with One Shear Bolt	35E Constant Velocity with One Shear Bolt	
PARKING JACK	2000 LB side wind		
SPROCKET + CHAIN	#60		
LOW PROFILE HOPPER HEIGHT	10.5"		
PSI REQUIRED TO RAISE AUGER	1200 PSI	1400 PSI	1600 PSI
HP REQUIRED (WITH DRY WHEAT)	60 HP	65 HP	75 HP
WHEEL THREAD	132"	132"	132" - 180"
TRANSPORT HEIGHT	13' 8"	13' 4"	13' 4"

### HEIGHT, REACH & WHEEL SPECIFICATIONS

MODEL	HEIGHT (A)			HEIGHT (B)			REACH (C)			REACH (D)		
	LOWERED	HALFWAY	RAISED	LOWERED	HALFWAY	RAISED	LOWERED	HALFWAY	RAISED	LOWERED	HALFWAY	RAISED
10-63	12'	28' 2"	43' 7"	6' 9"	14' 8"	22' 5"	32'	29' 4"	24' 2"	31' 4"	28' 10"	23' 4"
10-73	11' 2"	30'	47' 10"	6' 9"	16' 4"	25' 4"	36'	33' 4"	28'	35' 3"	32' 11"	27' 9"
10-83	11' 8"	34' 2"	55' 3"	6' 9"	18' 1"	28' 6"	41' 9"	38' 7"	32' 1"	40' 11"	37' 5"	29' 10"

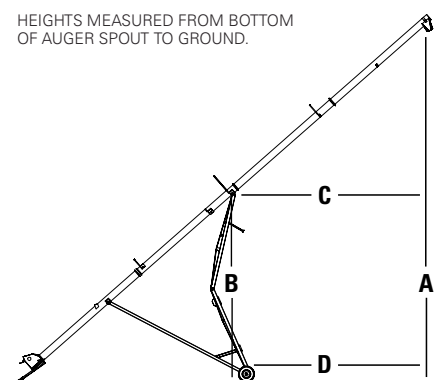

### HX130 | MX130 AUGER SPECIFICATIONS

	13-74	13-84	13-94
TUBING GAUGE	12 GA		
TUBE CONNECTORS	Heavy Duty $\frac{1}{4}$ " Angle Flange		
MAIN FLIGHTING	11 $\frac{3}{4}$ " OD x $\frac{1}{4}$ " Stretched + Welded (Extended Wear at Critical Transfer Points)		
UPPER BEARING	1 $\frac{3}{4}$ " Pillow Block Greaseable Ball Bearing		
LOWER BEARING	2" Pillow Block Greaseable Ball Bearing		
TUBE TRUSSING	$\frac{3}{8}$ " Aircraft Type Galvanized Steel Cable	2 $\frac{1}{2}$ " Steel Tube	
HYDRAULIC LIFT	Two 4" Single Acting Cylinders	Two 4 $\frac{1}{2}$ " Single Acting Cylinders	
UNDERCARRIAGE	4" x 10" Scissor-Lift		
AXLE	4" x 4" Square Tubing		
HUB	6 Bolt Agricultural Type		
TIRES	16" TRF		
PTO SHAFT	35E Constant Velocity with $\frac{3}{8}$ " Shear Bolt	55E Constant Velocity with 2-Bolt Shear	
PARKING JACK	5000 LB Side Wind		
SPROCKET + CHAIN	Hardened Tooth Sprocket with HD #80 Chain		
LOW PROFILE HOPPER HEIGHT	60" Length x 48" Width x 10 $\frac{1}{2}$ " Height with Flat Free Tires		
PSI REQUIRED TO RAISE AUGER	1500 PSI	1950 PSI	2050 PSI
HP REQUIRED (WITH DRY WHEAT)	125 HP	135 - 155 HP	145 - 165 HP
WHEEL TREAD	146"-182"		
TRANSPORT HEIGHT	11' 7"	12'	12'

### HEIGHT, REACH & WHEEL SPECIFICATIONS

MODEL	HEIGHT (A)			HEIGHT (B)			REACH (C)			REACH (D)		
	LOWERED	HALFWAY	RAISED	LOWERED	HALFWAY	RAISED	LOWERED	HALFWAY	RAISED	LOWERED	HALFWAY	RAISED
13-74	9' 2"	25' 8"	48' 8"	38' 7"	36' 7"	28' 1"	4' 6"	12' 7"	24' 4"	38' 7"	36' 9"	29' 7"
13-84	9' 5"	30'	55'	43' 9"	41'	34'	4' 6"	15' 9"	27' 5"	43' 9"	41' 3"	34' 8"
13-94	9' 2"	34' 4"	60' 1"	49'	46' 3"	37' 7"	4' 6"	17' 1"	30'	49'	46' 6"	38' 5"

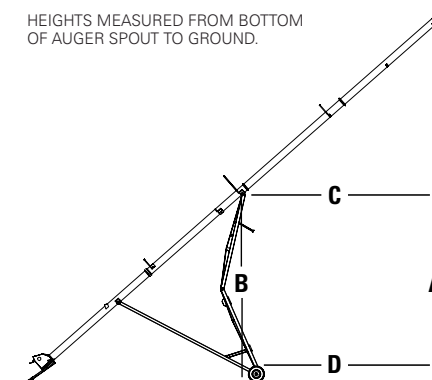



**Hutchinson | Mayrath is an AGI Brand.**

AGI is a leading provider of equipment solutions for agriculture bulk commodities including seed, fertilizer, grain, and feed systems with a growing platform in providing equipment and solutions for food processing facilities. AGI has manufacturing facilities in Canada, the United States, the United Kingdom, Brazil, South Africa and Italy and distributes its products globally.



P.O. Box 629, 74, Clay Center, Kansas, USA 67432  
785.632.2161 | hutchinson-mayrath.com

AGGROWTH.COM @aggrowthintl